

Shaft Speed : 1450 rpm

Outlet : 100mm, 4in

OUTPUT	HEAD	FLOW
3.7 kW	Rated : 11.1m, 36.4ft	Rated : 20 l/s, 317 gpm
5 HP	Max : 19.6m, 64ft	Max : 37 l/s, 581 gpm

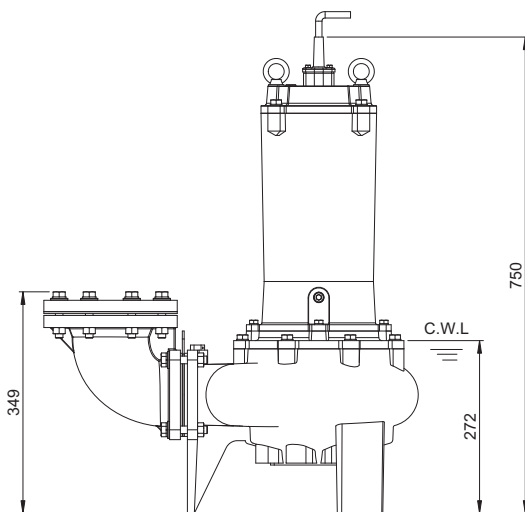
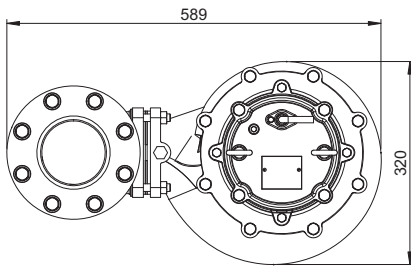

Weight : 97kg / 214 lbs

Pump Type	Electric Submersible Pumps	
	3-Phase	
Motor	Type	Induction Motor
	Poles	4 Pole
	Insulation	Class F
	Protector	Circle Thermal Protector
	Starter	D.O.L.
Lubricant	Food Grade (ISO VG32)	
Impeller Type	Single Channel	
Shaft Seal	Double Mechanical Seal	
	Silicon Carbide VS Ceramic / Carbon	
Bearings	C3 Shielded ball bearings	
Cable	H07RNF	
	Length: 10m (33ft) or longer upon request.	
Materials	Pump Casing	Gray Iron
	Impeller	Gray Iron
	Motor Frame	Gray Iron
	Motor Shaft	Stainless Steel
	Mouth Ring	Copper Alloy
Max. Liquid Temperature	104°F (40°C)	
Max. Submersion Depth	66ft (20m)	
pH Range	pH 5 - pH 8	
Accessories	GRN-03	